

# PRODUCT DATA SHEET

## SpecSeal<sup>®</sup> Series SSS Intumescent Sealant

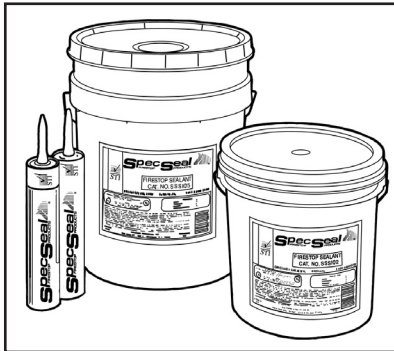

### FEATURES

- **Water-Based** for easy installation, cleanup, and disposal.
- **Two-Stage Intumescence** features extremely fast and directionalized expansion.
- **Endothermic Fillers** absorb heat & release water.
- **High Solids Formula** means no shrinkage!
- **Sandable & Paintable** (when dry)
- **Water-Resistant:** Will not re-emulsify when dry!
- **Safe:** Low VOCs, No Solvents
- **Red Color** for easy identification and inspection.
- **Multi Viscosity Grade** means excellent caulking properties along with high build capabilities.
- **Excellent Smoke Seal**

### 1. PRODUCT DESCRIPTION

SpecSeal<sup>®</sup> Series SSS Sealant is a latex based, high solids firestop compound. This material, when properly installed, will effectively seal penetration openings against the spread of fire, smoke, toxic gasses and water.

SpecSeal<sup>®</sup> Series SSS Sealant features STI's patented and proprietary two-stage intumescent technology. When exposed to high temperatures or fire, this material expands aggressively in a highly directionalized fashion to quickly close off voids left by the burning or melting of combustible materials.

SpecSeal<sup>®</sup> Series SSS Sealant's unique multi-viscosity formula yields a single grade that has excellent caulking properties as well as high build properties on vertical or overhead surfaces. This single grade may be pumped, caulked (standard cartridge or bulk loaded), knifed or troweled. In addition, SpecSeal<sup>®</sup> SSS does not contain PCB's or asbestos.

SpecSeal<sup>®</sup> Series SSS Sealant is storage stable (when stored according to the manufacturer's recommendations) and will not separate nor shrink when dried. SpecSeal<sup>®</sup> Series SSS Sealant will adhere to all common construction and penetrant materials and contains no solvents making it safe for use with most plastics.

### 2. APPLICATIONS

See Table A for a summary application list.

SpecSeal<sup>®</sup> Series SSS Sealant is used to seal through-penetrations as well as construction gaps and blank openings. Series SSS has been tested for use with metallic penetrants up to 30" (762 mm) trade size. This product is also used with other SpecSeal<sup>®</sup> Products such as SpecSeal<sup>®</sup> Firestop Collars and Wrap Strips.

### 3. PHYSICAL PROPERTIES

See Table B.

### 4. PERFORMANCE

SpecSeal<sup>®</sup> Series SSS Sealant is the basis for systems that meet the exacting criteria of ASTM E814 (UL1479) as well as the time-temperature requirements of ASTM E119 (UL263). Systems have been tested for all common forms of construction and most common penetrants with ratings up to 4 hours. STI firestop systems are designed to maximize the fire resistance of the seal by not only sealing off the spread of fire and hot gasses but also by minimizing the amount of heat conducted through the assembly.

### 5. SPECIFICATIONS

The firestopping sealant shall be a one-part, two-stage intumescent latex compound. The sealant when exposed to high heat or flame shall be capable of expanding a minimum of 8 times. Range of continuing expansion shall be from 230°F to >1,000°F (110°C to 538°C). The sealant shall be thixotropic and shall be capable of caulking or troweling onto vertical surfaces or overhead. The sealant shall be UL Classified and/or FM Systems Approved and tested to the requirements of ASTM E814 (UL1479).

#### SPECIFIED DIVISIONS

DIV.	7	07840	Through-Penetration Firestopping
DIV.	13	13900	Special Construction Fire Suppression & Supervisory Systems
DIV.	15	15250	Mechanical Insulation – Fire Protection
DIV.	16	16050	Basic Electrical Materials & Methods

## Table A: APPLICATIONS

### Tested & Classified for Fire Resistance

- **Metallic Pipes** including steel, iron, or copper pipe and tubing through all common constructions.
- **Nonmetallic Pipes, Conduits & Tubing** including PVC, CPVC, PVDF, PEX, PEX-AL-PEX, ABS, PB through all common constructions.
- **Cable, Cable Trays & Bus Duct**
- **HVAC Ductwork**
- **Insulated Pipes**
- **Multi-Service Penetrations** including AC line sets, electrical, telephone, or TV service entrance and interior penetrations.
- **Complete Wood Floor firestopping package** for electrical, plumbing, HVAC, TV and telephone.

## Table B:

### PHYSICAL PROPERTIES

<b>Product Name</b>	Series SSS Sealant
<b>Color</b>	Red
<b>Odor</b>	Mild Latex
<b>Density</b>	9.4 Lb/Gal (1.13 kg/L)
<b>Solids</b>	80% ± 2%
<b>pH</b>	8.3
<b>Expansion Begins</b>	230°F (110°C) 1st Stage 350°F (177°C) 2nd Stage
<b>Expansion Range</b>	230°F to >1,000°F (110°C to > 538°C)
<b>Volume Expansion</b>	> 500% Free Expansion
<b>Max. In-Service Temp.</b>	120°F (49°C)
<b>Flame Spread</b>	0*
<b>Smoke Development</b>	10*
<b>STC Rating</b>	51
<b>VOC Content**</b>	0.18 lbs/gal (22.0 g/l)

\* Tested to ASTM E84 (UL723) at 14% surface coverage (modified test for sealants and caulks)

\*\*ASTM D3960 and EPA Federal Reference Method 24

Shown below and on the following page are just a few of the most common applications for SpecSeal Series SSS Sealant. Consult the Technical Library at [www.stifirestop.com](http://www.stifirestop.com) for over 200 available designs utilizing this product.

**Fig. 1: METALLIC PIPE PENETRATIONS - CONCRETE/MASONRY FLOORS & WALLS**

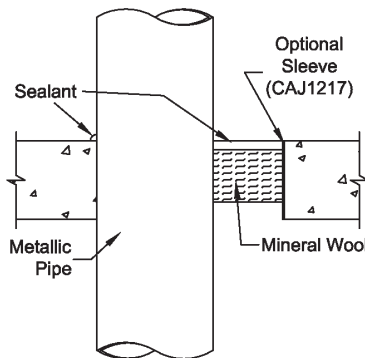

### UL SYSTEM C-AJ-1079

F Rating: 4 Hr • T Rating: 0  
Steel or Iron Pipe: 24", Copper Pipe 6"  
Annulus: Point Contact to 4" • Sealant Depth: 1/2"  
Forming Material: Nom 4 pcf Mineral Wool  
Thickness: 1-1/2" for 6" Steel or Iron Pipe  
3" for 4" Copper or 6" Iron or Steel Pipe

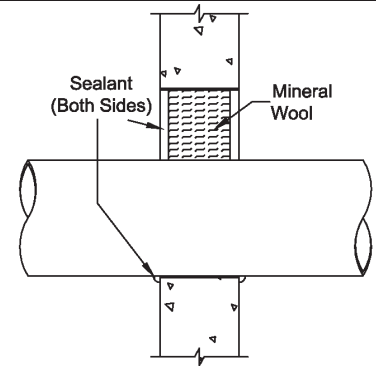

### UL SYSTEM C-AJ-1217

F Rating: 4 Hr • T Rating: 0  
Steel or Iron Pipe: 30", Copper Pipe 6"  
Annulus: Point Contact to 2" • Sealant Depth: 1/2"  
Forming Material: Nom 4 pcf Mineral Wool  
Tightly Packed to a 3" Depth.

**Fig. 2: INSULATED METALLIC PIPE PENETRATIONS - CONCRETE/MASONRY FLOORS & WALLS**

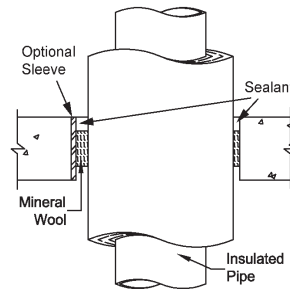

### UL SYSTEM C-AJ-5087

F Rating: 2 Hr • T Rating: 1  
Steel or Iron Pipe: 24"  
Insulated with 2" Thick Fiber Glass or Mineral Wool Pipe Insulation  
Annulus: 1/2" to 1-1/2" • Sealant Depth: 1/2"  
Forming Material: Nom 4 pcf Mineral Wool Tightly Packed to a 4" Depth.

**Table C: SEALANT REQUIREMENTS IN CUBIC INCHES PER 1/4 INCH OF INSTALLED DEPTH\***

Pipe Size		Diameter of Opening (in.)											
Trade Size	Pipe O.D.	1.5	2.0	3.0	4.0	5.0	6.0	7.0	8.0	10	12	14	26
0.5"	0.840	0.3	0.6	1.6	3.0	4.8	6.9	9.5	12.4	19.5	28.1	38.3	132.6
1"	1.315	0.1	0.4	1.4	2.8	4.6	6.7	9.3	12.2	19.3	27.9	38.1	132.4
1.5"	1.900			1.1	2.4	4.2	6.4	8.9	11.9	18.9	27.6	37.8	132.0
2"	2.375			0.7	2.0	3.8	6.0	8.5	11.5	18.5	27.2	37.4	131.6
2.5"	2.875			0.1	1.5	3.3	5.4	8.0	10.9	18.0	26.7	36.9	131.1
3"	3.500				0.7	2.5	4.7	7.2	10.2	17.2	25.9	36.1	130.3
3.5"	4.000					1.8	3.9	6.5	9.4	16.5	25.1	35.3	129.6
4"	4.500					0.8	3.0	5.6	8.5	15.6	24.2	34.4	128.7
6"	6.625							1.1	4.0	11.1	19.7	29.9	124.2
8"	8.625									4.9	13.6	23.8	118.0
10"	10.750										5.6	15.8	110.0
12"	12.750											6.6	100.8
24"	24.000												19.6

IMPORTANT NOTE: This table is for estimation purposes only. Consult UL Fire Resistance Directory or STI Product & Application Guide for specific installation requirements and limitations

Thus all systems have been designed to provide T Ratings capable of matching the rating of the wall or floor assembly (where possible) when tested without penetrants.

**5. SPECIFICATIONS**

See page 1.

**6. INSTALLATION INSTRUCTIONS**

General: Areas to be protected must be clean and free of oil, loose dirt, rust or scale. Installation temperatures must be between 35°F and 100°F (1.7°C to 37.8°C). Allow product to dry a minimum of 24 hours before exposure to moisture.

System Selection: Selection of an appropriate firestop system design is critical to the fire protection process. Space limitations preclude highly detailed information pertaining to individual application systems. Please consult the STI Product & Application Guide as well as the UL® Fire Resistance Directory for additional information.

Forming: Some installations may require forming as either an integral part of the system or as an option to facilitate installation. In systems where forming is required, mineral wool batts (1-1/2" to 3" nominal thickness, 4 lb./cu. ft. density) are recommended. Some gypsum wallboard systems utilize fiberglass. Cut forming material over-size to allow for tight packing. Position forming material to allow for the proper depth of fill material.

Fill Material: SpecSeal® Series SSS Sealant may be installed by caulking using a standard caulking gun or from bulk containers using a bulk loading caulk gun, or by manually troweling using a mason's trowel or putty knife. If the sealant tends to pull back from a surface, clean the surface with a damp rag or sponge and reapply. Work sealant into all areas exercising care to eliminate voids or seams. The surface of the sealant can be smoothed using a putty knife dipped in water. Adding water to the sealant itself is not recommended. Sealant (when dry) may be sanded and painted using most non-solvent based paints. In gypsum wallboard penetrations, crown sealant 1/4" (6.35 mm) from penetrant to wallboard surface at a point approximately 1/2" (12.7 mm) or more from opening.

**Fig. 3: ELECTRICAL, DATA OR COMMUNICATIONS PENETRATIONS - RATED GYPSUM WALLBOARD ASSEMBLIES**

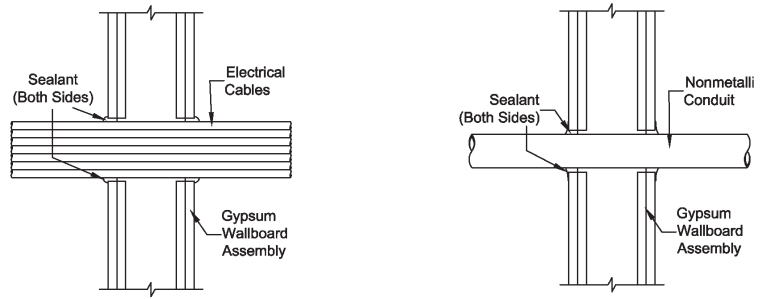

**UL SYSTEM W-L-3076**

F Rating: 1 or 2 Hr • T Rating: 0 hr  
Up to 4" Cable Bundle  
Centered in 4 - 1/2" Opening  
Sealant Depth: 5/8" with 1/4" Crown

**UL SYSTEM W-L-2093**

F Rating: 1 or 2 Hr • T Rating: 1, 1-1/2 Hr  
2" Rigid PVC, ENMT,  
or Optical Fiber Raceway,  
1-1/4" PVDF Optical Fiber Raceway,  
Sealant Depth: 5/8" with 1/4" Crown

**Fig. 4: ELECTRICAL PENETRATIONS - CONCRETE/MASONRY FLOORS & WALLS**

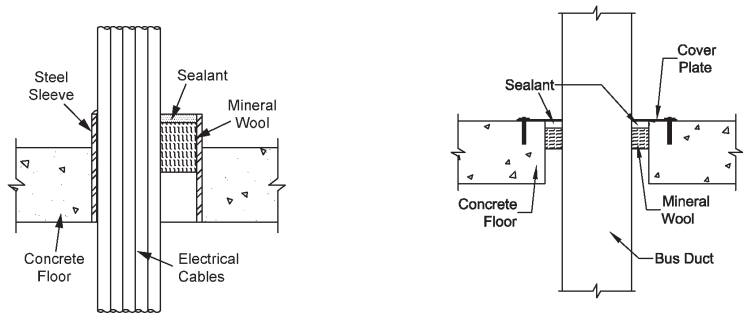

**UL SYSTEM C-AJ-3154**

F Rating: 1, 2, 3 & 4 Hr • T Rating: 0, 1/2, & 2 3/4 Hr  
Optional Sleeve-PVC or Steel  
Electrical, Telephone or Data Cables  
Annulus: 0" to 2"  
Sealant Depth: 1/2"  
Forming Materials: Nom 4 pcf Mineral Wool  
Sealant Depth: 1/2" for 1, 2, 3 Hr; 3/4" for 4 Hr

**UL SYSTEM C-AJ-6008**

F Rating: 3 Hr • T Rating: 0 Hr  
Aluminum or Copper Bus Duct 5,000 Amp  
Steel Cover Plate  
Sealant Depth: 1/2"  
Forming Materials: Nom 4 pcf Mineral Wool  
Tightly Packed to a depth of 1-1/2"

**Fig. 5: BARE & INSULATED METALLIC PIPE PENETRATIONS - RATED GYPSUM WALLBOARD ASSEMBLIES**

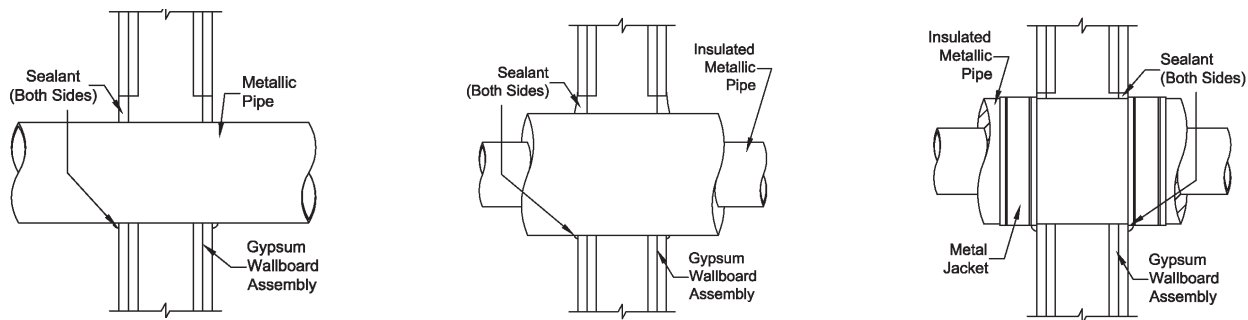

**UL SYSTEM W-L-1049**

F Rating: 1 & 2 hr • T Rating: 0 hr  
Steel or Iron Pipe: 24", Copper Pipe: 6"  
Annulus: Point Contact to 1-3/4"  
Sealant Depth: 5/8" with 3/8" Crown

**UL SYSTEM W-L-5014**

F Rating: 1 & 2 Hr • T Rating: 1 hr  
Steel or Iron Pipe: 12", Copper Pipe: 4"  
Insulated with 2" Thick Fiber Glass  
or Mineral Wool Pipe Insulation  
Annulus: 0" to 1-1/4"  
Sealant Depth: 5/8" with 3/8" Crown

**UL SYSTEM W-L-5051**

F Rating: 1 & 2 Hr • T Rating: 1-1/2 Hr  
Steel or Iron Pipe: 4", Copper Pipe: 4"  
Foam Glass Pipe Insulation: 2" Thick  
12" Wide 0.010" Thick Metal Jacket Wrapped Around  
Insulation and Secured with Metal Banding as Shown  
Annulus: 0" to 3/8"  
Sealant Depth: 5/8"



**Smoke Sealing:** In some applications including firestop collars, SpecSeal® Series SSS Sealant is recommended as a smoke seal. It is suggested in these applications that the sealant be applied to both sides of walls. In floor applications, a sealing bead is suggested top and bottom.

**Cover Plate:** In some designs a galvanized steel cover plate (26 gauge) may be used to upgrade the fire resistance rating to 4 hours. Consult STI Product and Application Guide for dimensional and fastening requirements.

**LIMITATIONS:** This product is water-based and cures through the evaporation of water. Low temperatures, high humidity, the use of non-porous or impermeable backing materials, cover plates or coatings may retard the drying process. Do not paint or seal in any way that prevents contact with air until sealant has dried through completely. This product has been designed to be safe with plastics and has been used extensively and successfully with a variety of different types of plastic pipes, tubes, and plastic cable insulations. Variations in these materials however, make it impossible to guarantee compatibility. STI strongly recommends that the user consult with the manufacturer of the pipe, tubing, or cable in question regarding any known sensitivities or potential restrictions before applying this product.

## 7. MAINTENANCE

**Inspection:** Installations should be inspected periodically for

subsequent damage. Any damage should be repaired using SpecSeal® products per the original approved design.

**Retrofit:** When adding or removing penetrants, care should be taken to minimize damage to the seal. Reseal using SpecSeal® products per the approved design. **NOTE:** New penetrants of a different nature than the original design may require a totally new firestop design or extensive modifications to the existing design. Reseal all openings as per the requirements of the modified design.

## 8. TECHNICAL SERVICE

Specified Technologies Inc. provides toll free technical support to assist in product selection and appropriate installation design. UL Systems, Material Safety Data Sheets and other technical information is available at the Technical Library at [www.stifirestop.com](http://www.stifirestop.com).

## 9. PRECAUTIONARY INFORMATION

Consult Material Safety Data Sheet for additional information on the safe handling and disposal of this material. Wash areas of skin contact with soap and water. Avoid contact with eyes. **SEALANT IS CONDUCTIVE UNTIL DRY.**

## 10. AVAILABILITY

SpecSeal® Series SSS Sealant is available from authorized STI distributors. Consult factory for the names and locations of the nearest sales representatives or distributors. Available packages and additional SpecSeal® Products are listed below.

### TABLE D: ORDERING INFORMATION

CAT. NO.	DESCRIPTION
SSS100	10.1 oz. Tube (300 ml) 18.2 cu.in.
SSS129	29 oz. Tube (858 ml) 52 cu. in.
SSS120	20 oz. Sausage (592 ml) 36 cu. in.
SSS102	2 Gal. Pail (7.6 liters) 462 cu.in.
SSS105	5 Gal. Pail (19.0 liters) 1,155 cu.in.

#### Additional SpecSeal Products...

#### SSP Firestop Putty

Available both in bar form and in pads, putty provides easy retrofit for through-penetrations and economical protection for electrical boxes.

#### SSB Firestop Pillows

Durable, monolithic pillows for installations requiring quick and easy retrofitting. Systems designed for pipes, cables and cable tray in all types of construction!

#### Intumescent Wrap Strips

Three grades of intumescent wrap strips provide an unmatched combination of flexibility, economy, and expansion (up to 30X). Systems for plastic pipes including FR Polypropylene up to 8" trade size!

#### Molded Firestop Collars

Easy to install, economical protection for ABS and PVC pipes (both solid and foam core) as well as CPVC, PVDF, and FRPP. Collars available up to 6" trade size.

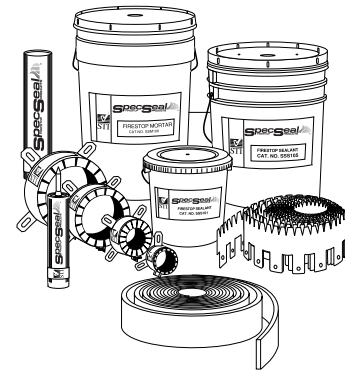

### CITY OF NEW YORK MEA 28-92M

Important Notice: All statements, technical information, and recommendations contained herein are based upon testing believed to be reliable, but the accuracy and completeness thereof is not guaranteed. **WARRANTY:** Specified Technologies Inc. manufactures its goods in a manner to be free of defects. Should any defect occur in its goods (within one year), Specified Technologies Inc., upon prompt notification, will at its option, exchange or repair the goods or refund the purchase price. **Limitations and Exclusions:** THIS WARRANTY IS IN LIEU OF ALL OTHER REPRESENTATIONS EXPRESSED OR IMPLIED (INCLUDING THE IMPLIED WARRANTIES OF MERCHANTABILITY OR FITNESS FOR USE) AND UNDER NO CIRCUMSTANCES SHALL SPECIFIED TECHNOLOGIES INC. BE RESPONSIBLE FOR ANY INCIDENTAL OR CONSEQUENTIAL PROPERTY DAMAGE OR LOSSES. PRIOR TO USE, THE USER SHALL DETERMINE THE SUITABILITY OF THE PRODUCT FOR ITS INTENDED USE, AND THE USER ASSUMES ALL RISKS AND LIABILITY FOR SUBSEQUENT USE. No statement or recommendation not contained herein shall have any force or effect unless in an agreement signed by officers of seller and manufacturer. **MADE IN THE USA – COPYRIGHT © 2004 SPECIFIED TECHNOLOGIES, INC.**



**Specified  
Technologies  
Inc.**

200 Evans Way • Somerville, NJ 08876  
Phone: (800) 992-1180 • Fax: (908) 526-9623  
STI on the WEB: [www.stifirestop.com](http://www.stifirestop.com)

